

# A CsI(Tl) detector array used in the experiment of the proton-rich nucleus $^{17}\text{Ne}^*$

MA Li-Ying(马立英) HUA Hui(华辉)<sup>1)</sup> LU Fei(卢飞) CHEN Dong(陈东)

JIANG Xi-Yao(姜希遥) YE Yan-Lin(叶沿林) JIANG Dong-Xing(江栋兴) Qureshi Faisal-Jamil

(School of Physics and State Key Laboratory of Nuclear Physics and Technology,  
Peking University, Beijing 100871, China)

**Abstract** To investigate the configurations of the valence protons in Borromean nucleus  $^{17}\text{Ne}$ , a CsI(Tl) detector array, which consists of 9 CsI crystals ( $26\times 26\times 20\text{mm}^3$ ) coupled with photodiodes, has been successfully used in the  $^{17}\text{Ne}$  experiment to measure the energy of protons. In order to find the optimal working conditions and get the best energy resolutions, several technologies (including various wrapping materials, wrapping and coupling methods) have been used. The testing results showed that the best energy resolution of the CsI(Tl) is about 3.3% using the  $^{241}\text{Am}$   $\alpha$ -source. The primary testing results with the proton beam were also provided.

**Key words** CsI(Tl), energy resolution, proton

**PACS** 29.40.Mc, 29.30.Ep, 25.60.-t

## 1 Introduction

There are various advantages for CsI(Tl) crystals as the sensitive matter of the scintillator detectors, such as: relatively high density, high luminescence efficiency, low prices compared to some other scintillators and quite easy to machining and so on.<sup>[1–3]</sup> Thus, it was widely used in the nuclear physics and particle physics experiments.

A CsI(Tl) detector array has been developed in Peking University and successfully used in the experiment of  $^{17}\text{Ne}$  to detect the protons. In this paper, the process of developing the CsI(Tl) detector array will be described in two sections. The first one focuses on the investigation of single CsI(Tl) scintillator detector, including the detailed technologies to improve the energy resolution of the detector. The integrated properties of the detector array were also present. The second section will introduce the performance of the CsI(Tl) detector array in the experiment of  $^{17}\text{Ne}$ , which was performed at RIBLL in IMP.

## 2 Single CsI(Tl) detector

The CsI(Tl) crystals ( $26\times 26\times 20\text{mm}^3$ ) we used were made by HAMAMATSU INC. It coupled with PD(S3204). To get the optimal energy resolution of the detector, several different wrapping materials and coupling methods were used. In our test, three radioactive sources ( $^{241}\text{Am}$   $\alpha$ -source,  $^{60}\text{Co}$   $\gamma$ -source,  $^{137}\text{Cs}$   $\gamma$ -source) were used. Comparisons with different technologies are listed in Table 1.

Table 1. Wrapping materials and coupling methods for CsI(Tl).

No.	incident face	four side faces	coupled face
1	Teflon films(1 mm slot)	Teflon films	silicon grease
2	2um Al-Mylar films	Teflon films	silicon grease
3	2um Al-Mylar films	2um Al-Mylar films	silicon grease
4	2um Al-Mylar films	Teflon films	glue
5	2um Al-Mylar films	TYVEK paper	glue

The test was done in a vacuum chamber. The output signals from the CsI(Tl) detector (CsI(Tl) crystals coupled with the PDs) were transferred to the

Received 3 September 2008

\* Supported by National Natural Science Foundation of China (10775005, 10735010, J0730316) and Chinese Major State Basic Research Development Program (2007CB815002)

1) E-mail: hhua@hep.pku.edu.cn

©2009 Chinese Physical Society and the Institute of High Energy Physics of the Chinese Academy of Sciences and the Institute of Modern Physics of the Chinese Academy of Sciences and IOP Publishing Ltd

pre-amplifier A250 and the amplifier ORTEC 572 A. After the amplification and shaping, the signals were analysis by the ADC. The high voltage for the PDs was supplied by the ORTEC 710 power supply. The test setup is shown in Fig. 1.

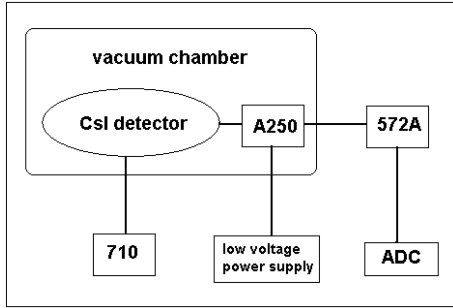

Fig. 1. The setup of test platform and electronics.

The typical  $^{241}\text{Am}$   $\alpha$ -source spectrum of a CsI(Tl) detector with the 5th wrapping and coupling conditions is shown in Fig. 2. Its energy resolution is about 3.3%.

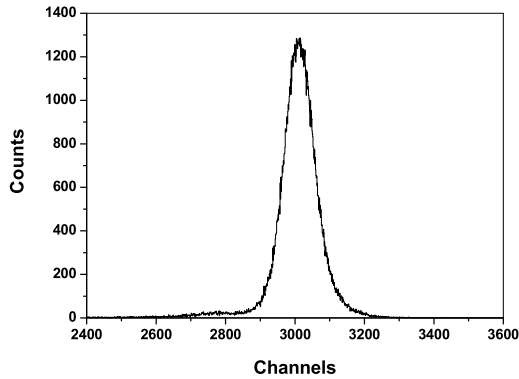

Fig. 2. The typical  $^{241}\text{Am}$   $\alpha$ -source spectrum of a CsI(Tl) detector with the 5th wrapping and coupling conditions.

The testing results with different technologies are shown in Table 2. In all the tests, the shaping time (6  $\mu\text{s}$ ) of the amplifier ORTEC 572 A and the PD high-voltage (70 V) supplied by the ORTEC 710 were the same. However, the gains of the ORTEC 572 A were a little different for various wrapping and coupling conditions. From the Table 2, we can see that the best energy resolution ( $\sim 3.3\%$ ) was obtained under the 5th wrapping and coupling conditions. The testing results with different ion sources are shown in Table 3.

We found that the shaping time of the amplifier ORTEC 572 A has influence on the energy resolution of the CsI(Tl) detector. The testing results with different shaping time are shown in Table 4. It can be

seen that the longer the shaping time is, the better the energy resolution obtained.

Table 2. Testing results ( $^{241}\text{Am}$   $\alpha$ -source).

wrapping and coupling conditions	peak positions	FWHM	energy resolutions
1	673.2	23.7	3.52%
2	1158.0	51.8	4.47%
3	1839.2	89.8	4.88%
4	2648.8	102.8	3.89%
5	3012.0	100.8	3.35%

Table 3. Testing results for the different ion sources under 5th wrapping and coupling conditions.

ion sources	peak positions	FWHM	energy resolutions
$^{241}\text{Am}$ $\alpha$ -source	3012.0	100.8	3.35%
$^{60}\text{Co}$ $\gamma$ -source	1257.4	73.0	5.80%
	1427.2	73.0	5.11%
$^{137}\text{Cs}$ $\gamma$ -source	716.3	68.7	9.58%

Table 4. The testing results with different shaping time( $^{241}\text{Am}$   $\alpha$ -source; the 5th wrapping and coupling conditions).

shaping time/ $\mu\text{s}$	peak positions	FWHM	energy resolutions
3	2937.2	103.6	3.53%
6	3012.0	100.8	3.35%
10	3114.5	102.6	3.30%

According to the testing results, the 5th wrapping materials and coupling methods were chosen to build the CsI(Tl) detector array, which is shown in Fig. 3. The energy resolutions of most of the CsI(Tl) detectors are around 3%—4% using the  $^{241}\text{Am}$   $\alpha$ -source.

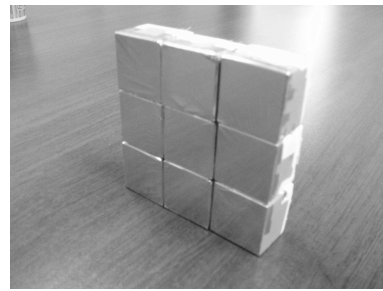

Fig. 3. The photograph of the CsI(Tl) detector array.

### 3 The performance of the CsI(Tl) detector array in the $^{17}\text{Ne}$ experiment

In the  $^{17}\text{Ne}$  experiment, the CsI(Tl) detector array was used to measure the deposit energies of protons. To get the energy calibration of CsI(Tl) detector for proton, the proton beams with different energies were used. The energies of the proton beams were

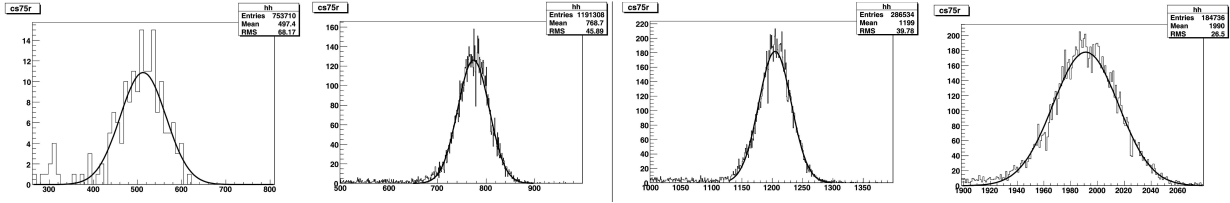

Fig. 4. The energy spectra of protons which were detected by the central CsI(Tl) detector of the array. (a) The energy of the proton beams is 8.0 MeV and its energy resolution is 23.82%; (b) 12.3MeV and 9.87%; (c) 18.9MeV and 5.23%; (d) 32.0 MeV and 2.89%.

8.0 MeV, 12.3 MeV, 18.9 MeV, 32.0 MeV, respectively. The energy spectra, which were detected by the central CsI(Tl) detector of the CsI(Tl) detector array, were showed in Fig. 4.

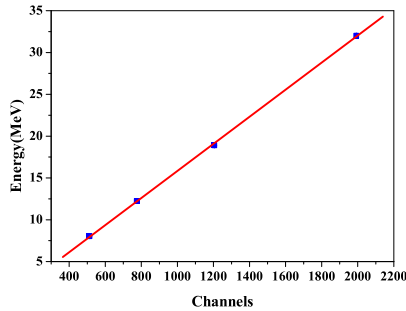

Fig. 5. Energy calibration curve for the CsI(Tl) detector.

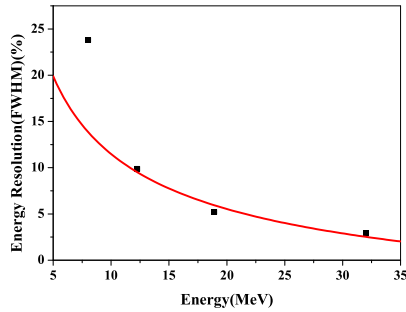

Fig. 6. The energy resolution of CsI(Tl) detector as a function of the energy of the proton beams.

Figure 5 shows the energy calibration curve for the CsI(Tl) detector. The good linearity of the energy calibration was obtained. Fig. 6 shows that how the energy resolution of CsI(Tl) detector varies with the energies of the proton beams. It can be seen that when the energies of the proton beams increase, the energy resolutions become better. Via fitting the experimental data, it has been found that the relationship between the energy resolution and the energy of the protons is consistent with  $\frac{\Delta E}{E} \propto E^{-\frac{1}{2}}$  except at the low energy. Since the energy spread of the proton beam at low energy region is larger than that at high energy region. This may cause the deviation of energy resolution at low energy.

## 4 Summary

The developing process of the CsI(Tl) detector array and its performance in the experiment of the proton-rich nucleus  $^{17}\text{Ne}$  have been reported in this paper. According to the testing results, the CsI(Tl)+PD detector can provide a good energy resolution for  $^{241}\text{Am}$   $\alpha$ -source, about 3.3% under the 5th wrapping and coupling conditions. In the  $^{17}\text{Ne}$  experiment, the CsI(Tl) detector array can provide a good energy resolution ( $\sim 2.89\%$ ) for 32.0 MeV proton beams. The linearity of energy calibration curve is also very good. The relationship between the energy resolution and the energy of the proton beams is consistent with  $\frac{\Delta E}{E} \propto E^{-\frac{1}{2}}$ .

## References

- 1 Birks J B. The Theory and Practice of Scintillation Counting, International Series of Monographs on Electronics and Instrumentation
- 2 Kubota Y et al. Nucl. Instrum. Methods A, 1992, **320**: 66—113
- 3 Abashian A et al. Nucl. Instrum. Methods A, 2002, **479**: 117—232